Workplace Health and Safety Queensland

Safe operation of an elevating work platform



Learning guide for operators of elevating work platforms

30497 QLD Course in Operating Cranes, Rigging and Scaffolding Equipment
Competency OHSCER235A Operate Boom-type Elevating Work Platform

Disclaimer:

Copyright protects this document. The State of Queensland has no objection to this material being reproduced, but asserts its right to be recognised as author of the original material and the right to have the material unaltered.

The material presented in this publication is distributed by the Queensland Government as an information source only. The State of Queensland makes no statements, representations, or warranties about the accuracy or completeness of the information contained in this publication, and the reader should not rely on it. The Queensland Government disclaims all responsibility and all liability (including, without limitation, liability in negligence) for all expenses, losses, damages and costs you might incur as a result of the information being inaccurate or incomplete in any way, and for any reason.

© *The State of Queensland Department of Justice and Attorney-General 2009.*

Contents

About this learning guide	5
Introduction	6
Chapter 1: Responsibility for workplace health and safety	7
Workplace health and safety: legal requirements	7
The employer's duty of care	7
Your duty of care / obligation to your employer and others	8
The duties of care of designers, suppliers and manufacturers	8
Consultation in the workplace	9
Chapter 2: Getting to know your elevating work platform	10
Introduction	10
Key learning areas	10
Parts of an elevating work platform	11
Types of elevating work platforms	16
Trailer-mounted EWP	16
Self-propelled EWP with scissor arms	16
Self-propelled EWP with telescoping boom	17
Self-propelled EWP with telescoping knuckle boom	17
Vehicle-mounted EWP	18
Chapter 3: Checking the equipment and work area and planning for the job	19
Introduction	19
Key learning areas	19
Finding out the job's requirements	20
Establishing work priorities	20
Finding out about all relevant workplace rules and procedures	21
First aid	21
Managing the risk in the workplace	22
Inspecting the work area	23
Work site hazard identification and control checklist	24
Planning for work near overhead powerlines including service lines	30
Working near exposed live parts	30
Exclusion zones	31
Definitions used in the exclusion zone table	31
What is a safety observer?	32
Types of safety observer	32
Exclusion zones safety observer	33
Summary of safety observer requirements	34
Authorisation zones	35
Exclusion zones in millimetres	37
Planning for work on a suspended floor of a building	40
Planning for the use of solvents or chemicals on the work platform	41
Planning for work above staff facilities	41
Planning emergency procedures	41
Workplace consultation	42
Conducting routine equipment checks before setting up the EWP	42
Routine pre-set-up equipment checklist	43
A simple reminder	47
Setting up the EWP	48
Starting up the EWP and making sure everything is working properly	49
Ground compartment checks	49
Checks for the platform	50
Chapter 4: Operation of the elevating work platform	51
Introduction	51
Key learning areas	51
Preparing for an elevation	51
Conducting an elevation	52
Moving the EWP	52
After moving the EWP	53
Other operational issues	53
Emergency procedures – contact with powerlines	54

Collapse of personnel in the basket	55
If the EWP starts to tilt to one side	55
If the motor cuts out	55
Emergency Decent Device procedures	55
Chapter 5: Shutting down the equipment and securing the site	57
Introduction	57
Shutting down the equipment	58
Lowering the machine	58
Stowing the machine	58
Lowering and stowing procedures for truck and trailer-mounted EWPs	58
Securing and stowing outriggers	58
Post-operational safety checks	59
Securing the site	59
Chapter 6: Getting a licence	60
Introduction	60
How to become a qualified elevating work platform operator	61
You must be supervised while you are being trained	61
Contacting an RTO for assessment	62
The assessment	63
After your assessment	63
Is a licence required?	63
What does your licence allow you to do?	63
Receiving your licence and beginning work	64
Using your licence interstate	64
Replacing a lost licence	64
Appendix A: Abbreviations	65
Appendix B: Contact details of OHS agencies	66

About this learning guide

This learning guide is divided into six chapters. Each chapter covers the basic things that trainees, supervisors and employers need to know for the safe operation of elevating work platforms.

Chapter 1: Responsibility for workplace health and safety

This chapter contains some important background information about legal requirements for employers and employees.

Chapter 2: Getting to know your elevating work platform

This chapter introduces the equipment and terminology used for typical elevating work platforms.

Chapter 3: Checking the equipment and work area and planning the job

Chapter 4: Operating an elevating work platform

Chapter 5: Shutting down the equipment and securing the site

These chapters cover the 'competencies' (knowledge and skills) that are needed for the safe operation of an elevating work platform. Each chapter takes a systematic, staged approach, covering the competencies that must be demonstrated in planning your work, doing the work and completing the work.

Chapter 6: Getting a licence

This chapter provides an overview of what you need to do to get a certificate, where to start and who is involved.

Appendix A: Abbreviations

Appendix B: Contacts details for OHS agencies

These appendices provide a handy reference list for abbreviations used in this Learning Guide and contact details for State and Territory occupational health and safety (OHS) jurisdictions.

Introduction

This learning guide has been developed to help people gain the knowledge and skills ('competencies') needed to operate an elevating work platform (EWP).

The 'competency' elements in this guide are taken from the National Occupational Health and Safety Certification Standard for Users and Operators of Industrial Equipment (NOHSC:1006 (2001)).

This national certification standard is part of a national certification system for users and operators of industrial equipment, and provides a framework for key learning objectives that are set out in this guide.

All Australian states and territories have legal requirements for operators of boom-type elevating work platforms to hold a certificate of competency to operate this type of equipment. If boom length of less than 11 metres usually no licence required.

You will find information on how to obtain a certificate of competency in Chapter 6.

This learning guide focuses on the competencies required to operate an EWP.

It does not deal with the operation of scissor lift platforms or other types of overhead work platforms for which operators are not required to hold a certificate of competency.

This learning guide focuses on EWPs, so all references in this guide are to these types of machines.

Chapter 1: Responsibility for workplace health and safety

Workplace health and safety: legal requirements

There are laws in all Australian states and territories to protect people against the risk of being injured or made ill because of the work they do.

In most states and territories these laws are called the Occupational Health and Safety Act or the Workplace Health and Safety Act.

These laws set out who is responsible for safety and what they must do. The responsible person has what is called a 'duty of care' or obligation.

Different people in the workplace have different 'duties of care' or obligation.

The employer's duty of care or obligation

Occupational health and safety (OHS) laws in Australia are very clear about who has the main responsibility for workplace safety.

Employers create the work situations which bring people and work systems, plant, equipment, chemicals and/or other hazards together. Accordingly, employers must take all reasonable steps to prevent people from being hurt at work.

Some of the duties of employers are very broad, such as 'an employer must ensure the health, safety and welfare at work of all employees of the employer'.

Others duties are quite specific, such as 'ensuring that any plant or substance provided for use by the employees at work is safe and without risks to health when properly used'.

The OHS laws say an employer must ensure the safety of its employees in whatever tasks they undertake on behalf of the employer. This includes the operation of plant and equipment such as elevating work platforms.

The employer's duty of care includes a requirement to ensure that everyone who operates an elevating work platform is qualified to do so (i.e. has a certificate), but it does not end there.

The employer is also required to make sure everyone who operates an elevating work platform has all of the necessary information, training and instruction to operate the elevating work platform in all of the work situations which may arise.

When you obtain your elevating work platform certificate, this certificate will simply be a statement that you have met the minimum 'competencies' required for safe operation. It will not remove your employer's duty to ensure that the work you do with the elevating work platform can be, and is, done safely. This means your employer must provide you with reasonable training and appropriate instruction and supervision even after you get your elevating work platform certificate.

In addition to having a duty of care for all employees, your employer is also responsible for the health and safety of other people in the workplace, including visitors, customers, contractors and casual workers. You need to be aware of this and understand the procedures used in your workplace to ensure the safety of others in the workplace.

You can see that the 'duty of care' obligations on employers are quite substantial and they must be diligent about safety in the workplace.

But this does not mean that you have no responsibilities. You do.

Your duty of care / obligation to your employer and others

You have a duty to take reasonable care for the health and safety of people who are at the employer's place of work.

You must also co-operate with your employer and anyone else at the workplace in order to enable your employer to meet his or her duties under the OHS laws.

The following is typical of the processes you may be required to do:

- Listen carefully to your employer's instructions. Know what you need to do and how you should do it.
- Follow the safety procedures applying at your workplace.
- Report any hazardous situations to your supervisor or employer.
- Advise your safety representative/supervisor or employer if there are any gaps in the safety procedures.
- Report any damage to equipment or plant to your supervisor.
- Tell your supervisor about any maintenance or repairs that need to be carried out on the equipment you are using and tag accordingly.
- Be aware of others in the workplace and co-operate with other work activities.
- Use the elevating work platform in a manner that does not endanger others in the workplace.

Only lift loads that are within the load rating of your machine

You always need to be mindful of other work activities that may be taking place in your work area.

You have a duty to co-operate with others about how work is to be conducted and, at times, the order in which work is to be done. You may need to consult with other workers, plan your work activity and work co-operatively with other workers to make sure that the tasks are completed safely.

Elevating work platforms are potentially very hazardous items of plant. They move around workplaces in areas where people are also moving about. This combination can create hazardous situations. You must always be aware of these hazards and make sure you do not operate the elevating work platform in a manner that puts yourself or others at risk.

Careless and reckless operation of an elevating work platform is a very serious matter. It may result in disciplinary action by your employer, as well as action by the authorities in your state or territory.

So be aware of the dangers, and always operate your equipment carefully and safely.

The duties of care of designers, suppliers and manufacturers

OHS laws in Australia also establish duties of care for designers, manufacturers and suppliers (including hirers) of plant, equipment and substances.

If you identify a design problem with the equipment you use, bring it to your employer's attention. Your employer can then take the matter up with the supplier or manufacturer, as they have an obligation to make sure that the equipment will not expose people to undue risk when used in accordance with the instructions.

Consultation in the workplace

An important feature about safety at work is the need for employers to consult with employees about the work they do. In some states and territories there are legal requirements for formal consultation mechanisms.

You may find that your workplace has a workplace health and safety committee or OHS representatives. The purpose of the committee and representatives is to allow health and safety issues to be meaningfully discussed and acted upon.

The process of consultation should allow people in the workplace to have a real say in matters that may affect their health and safety.

Employers should ensure there are established mechanisms for employees to be consulted about any hazards that may be present in the workplace and how these can best be controlled.

Similarly, employees need to have a say in the type of equipment or substances brought into the workplace.

The process of consultation also provides you with the opportunity to meet your OHS obligations and contribute to the safety of the workplace.

Make the most of your chance to have your say, by making your suggestions helpful and worthwhile.

Chapter 2: Getting to know your elevating work platform

Introduction

This chapter describes a typical elevating work platform and explains a number of general terms associated with elevating work platforms.

For the purposes of this learning guide an elevating work platform (EWP) is defined as:

‘A telescoping device, hinged device or articulated device, or any combination of these devices, which is used to support a platform on which personnel, equipment and materials can be elevated to perform work.’

Keep in mind that there are many different models and types of elevating work platforms. This chapter does not attempt to list every type.

Key learning areas

The main things you will learn in this chapter are:

Parts of an elevating work platform

You will become familiar with the different components of an elevating work platform.

Types of elevating work platforms

You will become familiar with the different types of elevating work platforms.

Typical elevating work platforms

How to use these diagrams

- Familiarise yourself with the key parts of the type of elevating work platform on which you are being trained.
- Refer back to these diagrams as the various parts of an elevating work platform are referred to in this guide.

Parts of an elevating work platform

Figure 2.1: Typical EWP with telescoping boom

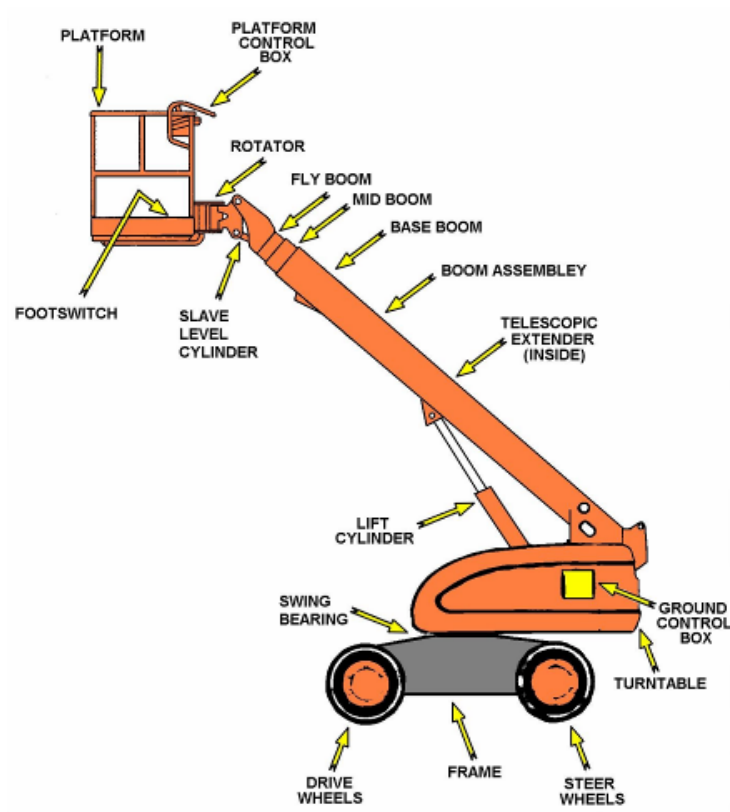

Figure 2.2: Typical EWP with telescoping knuckle boom

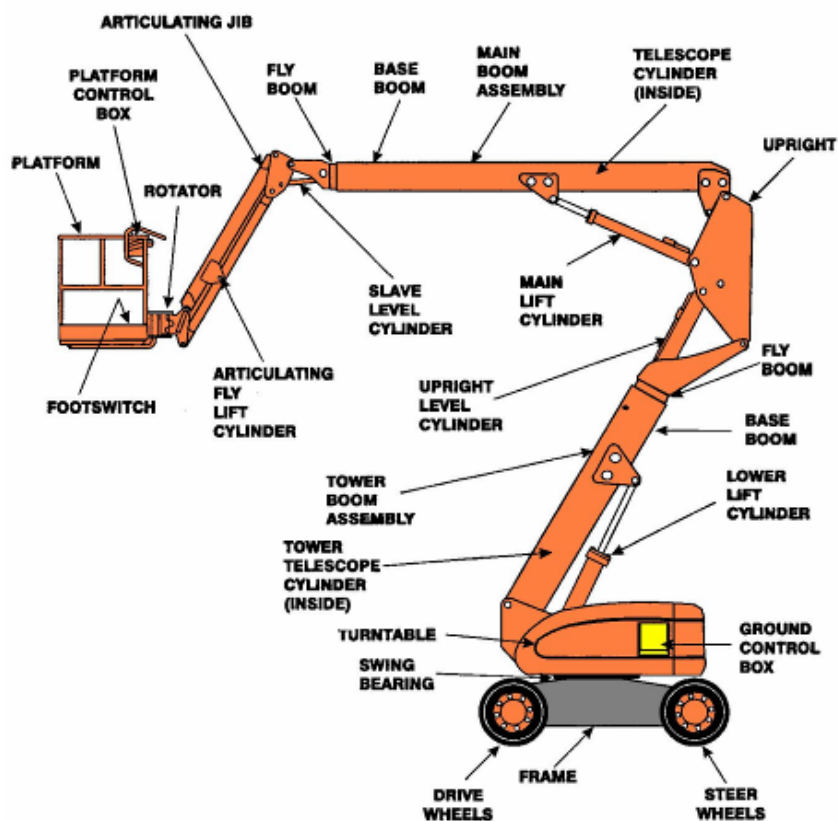

Figure 2.3a: Examples of base controls



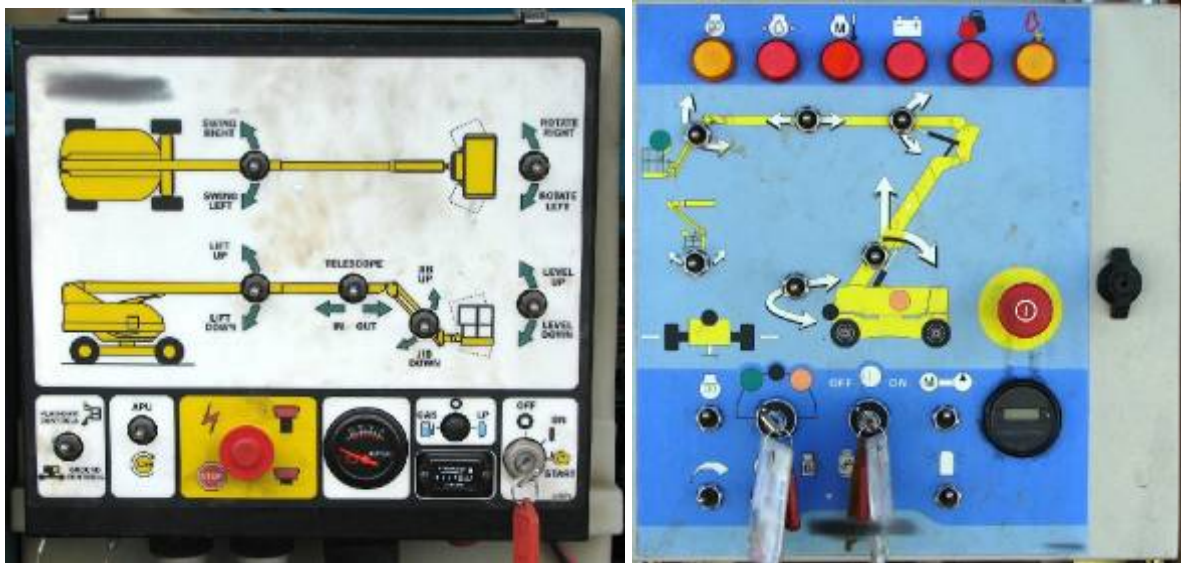

Figure 2.3b: Examples of remote and basket controls



Observer and basket remote controls



Scissor lift single joy stick control

Figure 2.3c: Examples of basket and stabiliser controls





Basket joy stick controls with deadman pedal



Stabiliser controls



Hydraulic basket controls

Types of elevating work platforms (EWP)

Trailer mounted EWP

These elevating work platforms are mounted on a moveable trailer and can be towed by most vehicles with a tow ball. They have manually adjusted stabilisers to provide stability for the platform while it is being used and have a range of working heights up to 26 metres.

Figure 2.4: Trailer mounted EWP



Self-propelled EWP with scissor arms

These EWPs are self-propelled units for use on flat concrete surfaces or firm unsealed areas.

The work platform is elevated by scissor arms which are powered by hydraulic cylinder(s). There are controls at ground level and on the platform.

These EWPs can be fitted with outriggers, and their maximum platform heights can be over 30 metres.

Note: Licensing for this type of EWP is not required under the National Standard for 'Persons Performing High Risk Work' [NOHSC:1017 (2006)]

Figure 2.5: Self-propelled EWP with scissor arms



Self-propelled EWP with telescoping boom

These EWPs are self-propelled units for use on flat slabs or firm unsealed areas. The work platform is elevated using a straight extension (telescoping) boom. There are controls at ground level and on the platform.

Figure 2.6: Self-propelled EWP with telescoping boom



Self-propelled EWP with telescoping knuckle boom

These EWPs are self-propelled units for use on flat slabs or firm unsealed areas. The work platform is elevated by a boom which has at least two main sections, with a knuckle between them, and is mounted on a turret which allows slewing. This arrangement permits the boom to reach up and over obstacles.

Both sections of the boom may incorporate a telescoping extension. There are controls at ground level and on the platform.

Figure 2.7: Self-propelled EWP with a telescoping knuckle boom



Vehicle-mounted EWP

These EWPs are usually road-registered trucks with a boom or knuckle boom mounted on the truck chassis.

The boom is mounted on a turret to allow slewing, and outriggers are fitted to the chassis. There are controls at ground level and on the platform.

Figure 2.8: Vehicle-mounted EWP



Chapter 3: Checking the equipment and work area and planning the job

Introduction

This chapter deals with what you need to do before you start operating an EWP.

It explains how you need to check the equipment and the worksite to make sure the machine is safe and hazards in the workplace are identified and suitably controlled.

It is very important for these checks to become part of your routine, something you naturally do before you start the job.

It is also vital to follow a set procedure in your preparations for work with an EWP, addressing all your work tasks in a systematic and orderly way.

An important part of this job planning is to prepare an operational plan for the EWP, very simply setting out the steps to be followed in the work process.

While it may not be compulsory to have an operational plan, it is often a good idea to write down your plan.

This way, you will make sure that you and others in the workplace know what you are going to do and when you will do it.

An operational plan also provides the basis for a work method statement, which will be required in some work situations.

Key learning areas

The main things you will learn in this chapter are:

Inspection of the work site

You will learn processes for planning your work, identifying hazards in your workplace and making sure there are appropriate control measures to prevent people getting injured.

Pre-operational checks

You will learn about the routine checks of the elevating work platform you need to carry out before you even start the motor.

Set up procedures

You will learn how to set up the machine and check that it will safely do the job required.

The 'work steps' in an operational plan

The 'work steps' in an EWP operational plan are likely to include those listed below. Each of these work steps is discussed in this chapter.

Work step	Explanation
Job requirements	Finding out what the job involves.
Priorities	Determining the best order in which to carry out the different tasks you have to perform.
Workplace rules and procedures	Finding out about any particular rules and requirements of the workplace.
Identifying hazards and control measures	Identifying anything on the site that could cause harm and deciding what you need to do about each of these hazards.
Workplace consultation	Working with others and ensuring everyone is consulted and informed about the work to be done.

Finding out the job's requirements

Knowing the requirements of each job is fundamental to carrying out the work safely.

There should be a clearly written work specification detailing the type of work to be conducted and the expected results.

Among other things, determining the job's requirements will help you in selecting the right machine and working out how many people will be needed for the job.

For example, it is important to know the height of the work to be undertaken and the tasks to be performed at this height. Checking this out before the work starts can save a lot of time and effort.

The key elements to consider when you are working out what the job involves are:

- the type of work to be done
- the location of the job, including site and environmental issues and other work activities in the area
- the height of the job
- whether any approvals are required
- the time within which the job is to be completed, and
- the expected results or 'outcomes'.

It is best to make a visual inspection of the site as part of your pre-operational planning checks, if this is possible.

If you or your employer cannot visit the site, you should try to gather as much information about the site before you agree to undertake the work.

This may involve asking a set of standard questions, developed by your employer, before you agree to do the job. These questions should address the matters listed above.

You also need to be aware of any special operating requirements, such as whether you will have to operate the EWP near power-lines, on a suspended floor or above staff facilities and whether solvents or other chemicals will be used on the work platform. (Responses to these special hazards are addressed later in this chapter and in Chapter 4.)

Establishing work priorities

If the work you have to do involves a number of tasks, it is important to establish the order in which these tasks will be undertaken.

Often the nature of the work will determine the priority of the tasks. For example, you may need to complete tasks at the greatest height first and then complete other tasks at progressively lower elevations.

Your work plan should clearly set out the order in which you will do the required work.

Finding out about all relevant workplace rules and procedures

All workplace rules and procedures must be observed.

It is essential to consult with relevant workplace personnel to establish what the rules and procedures are at each particular site or workplace, and then to co-operate with others at the workplace by following these set procedures.

In planning your work you should consider whether you need to consult with:

- the owners of the building or site
- government authorities
- local councils
- the site manager
- supervisors, and
- other trades.

Consider the particular regulatory requirements that may apply to the type of work being undertaken from the EWP.

It is also helpful to speak with the site foreman/safety officer or the person responsible for the work program.

Some of the workplace procedures will be statutory requirements, e.g. the need to hold a certificate of competency.

Other important procedures are likely to include a need to undertake site induction training if the work is to be conducted on a construction site.

You should check with the occupational health and safety (OHS) authority in your state or territory (see Appendix B) to confirm local requirements.

Workplace procedures often require operators to wear appropriate personal protective equipment (PPE).

The type of safety equipment that should be worn at all times by a person working from an elevating work platform includes:

- a safety harness (a full body harness with an energy-absorbing lanyard)
- a safety helmet/hard hat
- steel capped, rubber soled shoes
- a safety vest, and
- goggles.

Other PPE may also be required, depending on the nature of the work (e.g. a respirator, gloves, ear-muffs for hearing protection, sun screen and/or safety clothing).

First aid

You should locate and identify the first-aid kit and/or station that is available before starting work on any site. This is normally done during the site induction.

Managing risk in the workplace

Elevating work platforms are used in many situations that present unique hazards to the operator and others, including power-lines, trees and surrounding buildings.

You need to be aware of all the potential hazards on the site and make sure all necessary measures are taken to control the risks and prevent the hazards from causing any harm.

The processes described below are known as 'risk management', but as you will see there is nothing particularly difficult about what this means.

As explained in Chapter 1 of this learning guide, your employer must make sure your workplace is safe and there are adequate controls to prevent accidents and injuries.

You can help your employer to manage safety in the workplace through these three simple steps.

IDENTIFY all potential hazards

What does this mean?

There is a need to take a risk assessment of the area and look out for hazards or potential hazards that may cause a problem or endanger you or others.

How do you do this?

The easiest way is to walk around the work area, looking for anything that could be a problem (e.g. an open pit in the work area, power lines etc).

ASSESS the risks

What does this mean?

This means that you work out which things are the most serious.

How do you do this?

Ask yourself how seriously things in your work area might hurt or injure people and how likely it is to happen.

By doing this you work out which things you need to deal with first, especially if something is very dangerous and could seriously hurt people.

For example, an open pit would pose a serious risk to anyone on an EWP working nearby.

CONTROL the risks

What does this mean?

This is the action that must be taken to prevent people from getting hurt.

How do you do this?

It depends on the risk and the circumstances.

In the case of the open pit example, barricades would need to be placed around the pit to prevent unintended access to this area, or the EWP would need to be set up at a safe distance from this hazard.

Inspecting the work area

Your operational plan will need to have a risk control strategy addressing each of the following areas:

- the tasks to be performed
- identified site hazards (e.g. trenching, scaffolding)
- PPE requirements for EWP personnel
- barriers
- signage, including warning signs alerting people about the overhead work
- traffic controls
- lights/lighting, and
- public safety.

More details and a checklist are provided below.

In some situations specific types of warning/hazard signs may be required. Check whether you need to display these signs, and also whether the area needs to be barricaded or fenced off.

For example, in some work situations you may need to display 'OVERHEAD WORK IN PROGRESS' signs. Check the requirements with the site foreman/safety officer.

ALWAYS be aware of public safety.

Note: In some states, traffic cones and barricades must be installed by a registered traffic controller.

Your hazard identification and control measures should not be confined to the EWP itself. For example, equipment and tools on the work platform are potential hazards, because they could fall during movement or impede safe access for the EWP operator, so all tools should be placed in a fixed or removable box/basket and not left lying on the floor of the EWP.

Work site hazard identification and control checklist

Possible hazards	What you need to do	Control measures
Any personnel working above or below the work platform/basket	Be aware of others who may be working above, below or near the basket. Check with the site supervisor or relevant contractor to determine if this is happening.	Stagger working arrangements, if possible, to avoid other overhead workers. If this is not possible, take whatever action is necessary to ensure there can be no contact with personnel and no materials/substances can fall into the basket of the EWP.
Bridges	Check whether you will need to travel or work under bridges or walkways, including pipe and cable bridges between buildings, which may be a particular hazard because of their location and vulnerability.	Keep clear of bridges.
Overhead service lines. The term 'overhead service line' has a particular meaning in the Electrical Safety Act 2002 (QLD) and is an overhead electric line, typically between the electricity distribution system and an electricity customer's building or pole.	These are usually fixtures inside buildings, and include pipes, cables, sewer lines and cable trays. They need to be kept under observation and avoided at all times. If the service lines are outside, they are usually supported by a pipe/cable gantry or bridge.	Do not elevate the EWP to come within the legislated exclusion zone (refer to the Code of Practice - Working Near Live Parts).

Possible hazards	What you need to do	Control measures
Dangerous materials	<p>Check whether you and/or others may come into contact with hazardous substances on the site or have to work with this type of material.</p> <p>Obtain information and follow directions from the relevant Material Safety Data Sheet(s) supplied with the chemicals.</p>	<p>Extreme care must be used when identifying, handling or applying hazardous materials.</p> <p>For example, do not mix a cocktail of different chemicals in the basket. If you get it wrong 20 metres up, you will have nowhere to escape. Mix the chemicals on the ground and take only the required amount up in the basket, in a sealed container.</p> <p>Make sure you are wearing the correct personal protective equipment (PPE). This can be identified by reading the material safety data sheet (MSDS).</p> <p>If you suspect or detect any hazardous substances, other than any you are working with, notify the site foreman/safety officer or an authorised person to have the materials removed.</p> <p>Do not attempt to move the materials yourself, as you may not have the correct personal protective equipment (PPE) and you could suffer permanent health damage.</p> <p>More detailed advice is provided at the end of this checklist table.</p>
Lack of Adequate Lighting	<p>Ensure the work area will be well lit. If your work will be performed at night or under fading light, there may be a potential hazard.</p>	<p>If the work area is not well lit, sufficient artificial lighting must be supplied over the whole working area. If you have any difficulty seeing, all work must stop until suitable lighting is provided.</p>
Obstructions	<p>On construction sites, check whether other plant and equipment or site materials might obstruct the path of the EWP.</p>	<p>Refer to the site management plan, if one is available, and consult with the site foreman/safety officer to advise them of your work program.</p>
Staff facilities	<p>Check for any staff facilities in the work area, such as washrooms, toilets, lunchrooms, meeting areas, first-aid rooms, work sheds, etc.</p>	<p>Working may be carried out above these facilities provided there is adequate, sufficiently strong overhead protection and slewing is avoided or kept to a minimum.</p> <p>Provide any necessary fencing or barricades in an area beneath the EWP's basket and make sure an alternative access/exit is provided.</p> <p>Stow tools and gear safely, and use lanyards if this is possible.</p> <p>More detailed advice is provided at the end of this checklist table.</p>

Possible hazards	What you need to do	Control measures
Ground conditions	<p>Inspect ground conditions in the site area. Check whether the ground surface has been affected by excavations or trenching which has now been filled or is wet and soft.</p> <p>Confirm the ground conditions with the site foreman/safety officer and/or other personnel on site.</p>	<p>Put adequate packing under the outriggers/stabilisers to spread the load over a larger area. If the ground is level, extend the outriggers until the tyres are approximately 50mm off the ground. Otherwise, extend the outriggers fully and then lower the top side outrigger until the machine is level.</p> <p>The machine must be level at all times.</p> <p>When setting up an EWP close to an open trench, make certain that no part of the machine is closer to the trench than the depth of the trench (e.g. if the trench is 1m deep, set up at least 1m away). If the ground is white sand or unstable, you may have to be much further away. If you are not sure how far away you will need to be, ask a competent person to assess the ground conditions.</p>

Possible hazards	What you need to do	Control measures
Powerlines	Inspect the site to see if there are power-lines in or near the work area.	<p>An EWP must not be operated within the exclusion zone prescribed for power-lines. This distance varies in different states and territories, so you will need to find out the legal requirement in your state or territory. There may be other regulatory requirements in addition to exclusion zone distance provisions.</p> <p>A person requires safe systems of work when work is to be carried out closer than the untrained person exclusion zones. To work closer, you either have the line proven de-energised or work up to the exclusion zone applicable for an authorised or instructed person. Part of the authorisation process is gaining approval from the person in control of the line. The person in control could be a person other than an electricity entity.</p> <p>Report all operations near power-lines to your supervisor/ employer. Your supervisor/employer must make sure that the work area is safe before work is carried out. Make sure that the EWP has appropriate barricades erected to keep members of the public and/or others from moving into the work area. Suitable PPE such as hard hats must be provided. Remember, you do not have to touch power-lines to be electrocuted. Electricity can jump a gap to the nearest conductive point. More detailed advice is provided at the end of this checklist table.</p>
Members of the public and site visitors	Ensure members of the public and visitors to your place of work are not exposed to a risk of injury or illness from your work.	<p>Before setting your machine up in an area where the public has access, contact the site manager, local council or other relevant organisation for instructions and site requirements.</p> <p>Put barricades, bunting, signs and cones around the work area and make sure every feasible measure is taken to secure the area.</p> <p>Make sure the rotating light and audible beeper on the machine is operating.</p>

Possible hazards	What you need to do	Control measures
Surrounding structures	Check the locations of buildings, towers, sheds, warehouses, advertising hoardings and other types of structures within or near the EWP's work zone.	Take care when operating near structures. Do not elevate the EWP into a position where it may come into contact with a surrounding structure.
Traffic and other machinery	Be aware of the traffic conditions on and near the site. Consult with the site foreman/safety officer, the site management plan and/or the local council in assessing traffic conditions.	Traffic control varies from state to state and from council to council. A permit must be obtained before you may set up a machine in a street or public place. Many councils require barriers, signs and cones to be set up by traffic controllers. Make sure the flashing light and audible beeper on the machine are operating. Avoid other machinery on the site.
Trees	Overhanging branches can be a hazard if they are too close to the work area. Check whether there is a risk of entanglement with the machine, work equipment or personnel.	If a tree is in the way and has to be pulled back slightly to allow access, use a tarpaulin to wrap up the branches and use ropes connected to the tarpaulin to pull the tree away. If you have to pull the tree by the trunk, special bark protecting slings are available.
Underground services	Check for the presence of underground services like electric, telephone and fibre optic cabling, gas supplies or water, drainage or sewer pipes. On construction sites these are often a major problem, as they are normally freshly laid, and even though the soil covering them has been compacted it may not support the weight of the machine. This can cause the machine to become unstable (and perhaps overturn) and can also damage the underground services.	If possible, keep clear of underground services. Seek advice from the supply authorities about whether you can overcome this problem by placing adequate packing under the outrigger/stabiliser pads to spread the load over a larger area (e.g. railway sleepers or steel plates with timber on the top). Do not use steel plates without timber on the top unless the machine is self-propelled, because steel outriggers slip very easily on a steel plate. If you are not sure of the ground surface, ask a competent person to provide a professional ground analysis.

Possible hazards	What you need to do	Control measures
Weather conditions	The machine must not be used outside during wind, rain, snow or stormy conditions.	<p>Later model machines (1990s onwards) have a wind speed capability on their compliance plate. If the maximum wind speed for your machine is less than 12.5 metres per second, the machine is for indoor use only!</p> <p>During high winds, conductors will sway with the breeze. This needs to be considered in maintaining exclusion zones.</p> <p>The machine must not be used if there is a potential for a lightning strike.</p> <p>If you need to shut the machine down because of rain, recheck the ground conditions before starting up again, and if necessary relocate the EWP to more stable ground.</p>

Planning for work near all overhead powerlines including service lines

Elevating work platforms are frequently used for work near powerlines because they are designed to provide work access at height.

When you are visiting the site before work commences, in order to identify the hazards and determine the necessary control measures, you should pay particular attention to any powerlines that might affect your work.

Overhead powerlines have become so much a part of the outdoor landscape that it is easy to forget they are there.

When you are busy working and you are watching something else, you may not realise how close you are coming to powerlines carrying high or low voltage electricity.

Contact with these lines, or with other objects touching these lines, is often fatal.

Even if you can't see the powerlines, or if you think you are not too close to them, the danger is always there.

When working near powerlines you must always assume that all the lines are 'live' and uninsulated, unless they have been positively identified as being de-energised and isolated.

Some EWPs are fitted with insulated booms however this insulation may not be adequate protection for working close to powerlines. When working near powerlines, you must at all times observe the specific, legislated exclusion zone/s. An elevating work platform fitted with an un-insulated boom must maintain a specific distance from overhead powerlines. Exclusion zones still apply where an insulated boom is being used.

If work is going to be conducted near powerlines inside the exclusion zones, a trained, competent person should be assigned the role of safety observer, to signal and warn you if any part of the machine comes closer than the specified safe distance from the powerline.

Do not let the prospect of having a job done quickly turn into a tragedy. Always maintain a safe distance from electrical wires.

Working near exposed live parts

Working near exposed and electrically live parts (such as overhead electric lines, electric wiring or underground cables) without proper precautions has the potential to kill and seriously injure.

Even if you don't touch the exposed live parts you are still in danger, as high-voltage electricity (more than 1000 volts) can arc, or jump gaps.

Working safely around electricity in electric lines, around buildings, underground cables or even when repairing equipment is subject to a code of practice.

The [Code of Practice - Working Near Exposed Live Parts](#) applies to people such as:

- crane operators
- plant operators
- painters
- carpenters
- people erecting or working on scaffolds
- sign makers
- agricultural workers
- carriers of high loads
- electrical repairers
- builders working near exposed live parts
- anyone who clears vegetation near overhead lines, and
- electrical workers.

If you do not fit into one of these categories, but are working around exposed live parts, the code of practice still applies to you.

Exclusion zones

High-voltage (more than 1000 volts or 1 kilovolt) can arc, or jump across gaps. So even if you don't touch the electric wire, you are still in danger of electrocution.

An exclusion zone is the space that exists around a live electrical part, including electric lines, the exposed ends of electric cabling or the exposed parts of electrical equipment.

Any work that could breach the exclusion zone requires a [safety observer](#).

Find out what the [different exclusion zones are](#).

Definitions used in the exclusion zone table

Authorised person – a person who:

- has enough technical knowledge and experience to do work that involves contact with, or being near to, the electrical part; and
- has been approved by the person in control of the electrical part to do work that involves contact with, or being near to, the electrical part, or is authorised to act for the person in control of the electrical part.

However, it should be noted that for operating plant operated by an authorised person or instructed person who does not have a safety observer or another safe system as required under the schedule, the authorised person or instructed person must be taken to be an untrained person.

High voltage – any voltage over 1000 volts (or 1 kilovolt).

Instructed person – for an electrical part, means a person who is acting under the supervision of an authorised person for the electrical part.

Low voltage – any voltage up to 1000 volts.

Operating plant – plant being operated for its intended purpose, but where the operation of the plant can materially affect the distance between the plant and any electrical part that has an exclusion zone around it. Some examples include:

- a tip truck tipping a load
- a fixed crane operating at a building site
- a concrete pumping truck.

Untrained person – a person who is not an authorised person or an instructed person for the electrical part. However, it should be noted that for operating plant operated by an authorised person or instructed person who does not have a safety observer or another safe system as required under the schedule, the authorised person or instructed person must be taken to be an untrained person.

Vehicle – does not include operating plant or aircraft.

What is a safety observer?

A safety observer is a person who has the responsibility of observing the work and can enter the regulated minimum safe distance.

A safety observer has **specific responsibilities** in relation to warning, rescuing and stopping the work being undertaken.

The self-employed operator or the operator's employer is responsible for appointing a safety observer. A safety observer is required for the following types of work:

- any work that may breach exclusion zones
- live low-voltage work and
- live high-voltage work.

A safety observer zone is larger than the specified minimum working distance (or exclusion zone). The safety observer zone comes into force when there is a risk that the crane or any part of the crane might enter the exclusion zone during its operation.

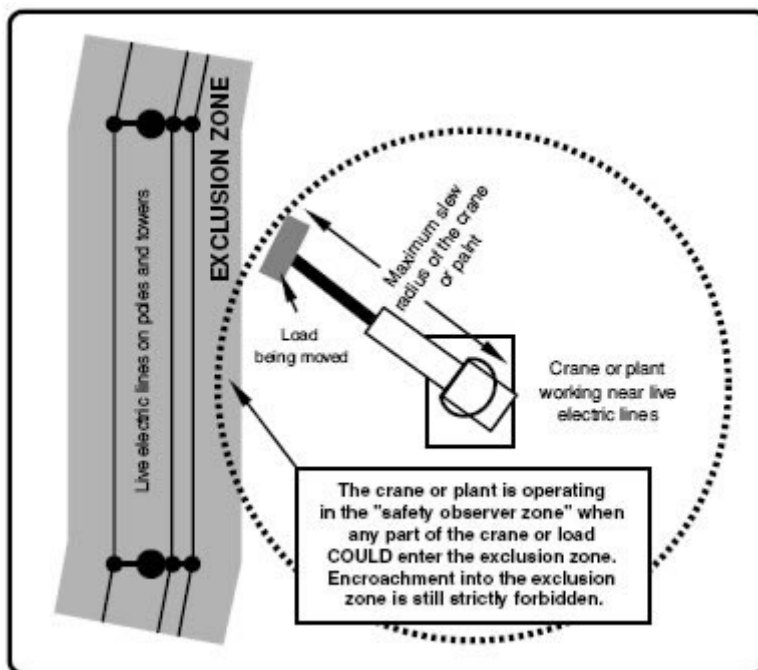

The safety observer zone is designed to encourage plant operators to locate their equipment so that the risk of it entering the exclusion zone is minimal. When this is not possible, adopt other suitable precautions to prevent encroachment into the exclusion zone.

A crane or plant is **not operating** in a safety observer zone when:

- the electric lines have been de-energised and earthed for high-voltage lines
- limiting devices have been installed to warn the operator or prevent any part of the crane, plant or load from entering the exclusion zone, or
- physical barriers are used to prevent any part of the crane, plant or load being moved from entering the exclusion zone.

For more information on the role of the safety observer for the safety observer zone, refer to [section 5.5.3](#) of the *Code of Practice - Working Near Exposed Live Parts*.

Types of safety observer

[Exclusion zone safety observer](#)

[Low voltage safety observer](#)

[High voltage safety observer](#)

Exclusion zone safety observer

The safety observer for exclusion zones should be a person who is able to perform the task, that is, the person should:

- be competent in observing, warning and communicating effectively (this may mean the use of electronic communications, e.g., a two-way radio)
- be hazard and risk aware
- be able to warn about approach to electrical apparatus
- be able to stop the work if necessary
- not be expected to observe more than one crane or plant at a time
- not be located in an elevated work platform, and
- not be assigned to other duties.

This type of safety observer is required when work is performed **near exposed live parts**.

For more information on the role of the safety observer for the safety observer zone, refer to [section 5.5.3](#) of the *Code of Practice - Working Near Exposed Live Parts*.

The other two safety observers mentioned are required [for electrical work that involves live work](#).

Low voltage safety observer

A safety observer for work on live low voltage has similar requirements as above, as well as:

- Be competent to help with the electrical work. This does not mean that the safety observer must be the holder of an electrical work licence, or be able to perform the electrical work themselves (e.g. an electrical engineer). To 'help' is to assist or facilitate the performance of the work.
- Be competent in isolation techniques.
- Not observe more than one task at a time.
- Be competent to:
 - rescue the person performing the electrical work, and
 - provide resuscitation (assessed in the last six months), and
 - be able to provide assistance in emergencies.

High voltage safety observer

A safety observer for work on live high-voltage overhead lines has similar requirements, in addition to those for working on low voltage:

- Be competent to perform the electrical work being performed. This would include having the appropriate electrical work licence.
- Be competent in warning of a lack of compliance with procedures and unsafe actions, and
- Not be required to be competent in isolation techniques.

A safety observer must be trained to perform the role. However, this training does not have to be formalised.

Summary of safety observer requirements

Exclusion zone safety observer	Low voltage safety observer	High voltage safety observer
Should* be hazard and risk aware	Must be hazard and risk aware	Must be hazard and risk aware
Should* be assigned to no other duties, other than as safety observer to observe, warn and communicate	Must be assigned to no other duties, other than as safety observer to observe, warn and communicate	Must be assigned to no other duties, other than as safety observer to observe, warn and communicate
Should* not observe more than one crane or plant at a time	Should* not observe more than one crane or plant at a time	Not a requirement
Should* not be positioned in an elevating work platform basket	Should* not be positioned in an elevating work platform basket	Must maintain a suitable position to observe the work
Should* be appropriately skilled in observing, warning and communicating effectively; and who warns about: approach to electrical apparatus unsafe conditions	Must be appropriately skilled in observing, warning and communicating effectively; and who warns about: approach to electrical apparatus unsafe conditions	Must be appropriately skilled in observing, warning and communicating effectively; and who warns about: potentially unsafe actions lack of compliance with approved work documentation
Should* be able to stop the work being performed	Should* be able to stop the work being performed	Must be able to stop the work being performed
	Must be competent to help with the electrical work. The safety observer does not need to hold an electrical work licence or do the work themselves. To 'help' is to assist or facilitate the work being performed	Must be competent to perform the electrical work being performed. This means that the safety observer must be the holder of an electrical work licence

	Must be competent in isolation techniques where appropriate	Not a requirement
	Must provide assistance in emergencies and be competent to: rescue the person performing the work provide resuscitation to the person performing the work (assessed in the last six months)	Must provide assistance in emergencies and be competent to: rescue the person performing the work provide resuscitation to the person performing the work (assessed in the last six months)

*A reference to 'should' is to something that is equivalent or better.

Authorisation zones

An authorisation zone occurs when an authorised or instructed person is permitted to have direct contact with, or to work within the exclusion zone for an insulated low-voltage line.

If an operating plant is to enter the authorisation zone, a safety observer or another safe system of work must be used. This is to prevent contact between the operating plant and the low-voltage line. When contact is permitted, then the safety observer is to prevent damage to the low-voltage line.

A safe system of work may include:

- A safe approach distance between the low-voltage electric lines and operating plant, usually of one metre or greater to prevent contact or damage to the line.
- The use of limit switches to prevent the operating plant from contacting the line, and
- Positioning and design of the operating plant to prevent contact with the line.

A safety observer **must be used** if work with the operating plant involves contact with an energised, insulated low-voltage line as required by regulations.

[Section 5.5.4](#) of the *Code of Practice - Working Near Exposed Live Parts* provides more information on the role of safety observers for the authorisation zone.

Who is an authorised person?

An **authorised person** is:

- a person who has enough technical knowledge and experience to undertake work that involves contact with, or being near to, the energised electrical part
- someone who has also been authorised by their employer and
- approved by the person in control of the electrical part or powerline concerned.

How do I become an authorised person?

In order to authorise a worker, the employer or self-employed person must first gain approval from the person in control of the electrical part to do work that involves being near to the electrical part. The employer or self-employed person would need to ensure that the person has enough technical skill and knowledge to perform the work.

In many instances, approval would need to be sought from an electrical entity. However, if it is a private electric line, the owner would need to approve the person to work near the line. For example, if the line is on a farm, the employer or self employed person would need to seek approval from the farm owner. Once the approval is gained from the person in control, the employer or self employed person will need to authorise the worker to do the work.

Some electrical entities require persons to have certain training before they will allow them to do work near their electricity networks.

Your industry organisation or local electricity entity may provide you with information and advice on training providers. The Department of Justice and Attorney General does not approve or endorse the training content of these providers.

Contact details for electricity entities

Country Energy	13 23 56
Energex	13 12 53
Ergon Energy	13 10 46
Powerlink	1800 353 031

Exclusion zone in millimetres

(Extract from the *Code of Practice – Working near exposed live parts*)

This information is from schedule 2 of the [Electrical Safety Regulation 2002](#).

Nominal phase to phase voltage (kV) (Exposed unless otherwise specified)	Untrained Persons			Instructed Persons (IP) and Authorised Persons (AP)								
	Untrained Persons	Operation of operating plant	Operation of vehicle	Instructed Persons (IP) and Authorised Persons (AP)	Operation of operating plant, with safety observer or another safe system		Operation of vehicle					
					Un-insulated	Insulated						
Insulated low voltage with consultation and insulation verified by AP	No contact	1000	300	Contact allowable	-	Contact allowable	No contact					
Low voltage (LV) with consultation	1000	3000	600	IP - no contact AP - insulated contact only	1000	Contact allowable	600					
Low voltage (LV) without consultation	3000											
> LV & up to 33 with consultation	2000	3000	900	700	1200	700	700					
> LV & up to 33 without consultation	3000											
> 33 & up to 50								2100	750	1300	750	750
> 50 & up to 66									1000	1400	1000	1000
> 66 & up to 110										1800		
> 110 & up to 132				1200			1200					
> 132 & up to 220	4500	6000	2900	1800	2400		1800					
> 220 & up to 275	5000			2300			3000	2300				

> 275 & up to 330	6000		3400	3000	3700		3000
> 330 & up to 400		8000	4400	3300	4000		3300
> 400 & up to 500				3900	4600		3900
Nominal Pole to Earth dc Voltage (kV)							
+/- 25	3000	3000	900	700	1200	700	700
+/- 85	3000		2100	1000	1800	1000	1000
+/- 150	3000			1200			1200
+/- 270	4500	6000	2900	1800	2400		1800
+/- 350	5000			2500	3200		2500
+/- 400	6000		3400	2900	3600		1900

Notes:

These exclusion zones apply to any part of a person, including any extension of the person such as a tool or vehicle, unless the extension of the person is an insulated device and has been tested as safe to be used on or near the live part.

Any work carried out which is intended to bring a person (including any extension of the person) closer than these exclusion zones is live electrical work and must be carried in accordance with the Electrical Safety legislation.

For meaning of instructed person, authorised person and untrained person, refer to *Code of Practice - Working near Exposed Live Parts*, [Appendix A](#).

5.3 Exclusion zone

Exclusion zone for operating plant means the exclusion distances as listed in [Appendix B](#) for operating plant working near live electric lines.

A person must not operate any crane or plant in situations where:

- any part of the crane or plant
- a person working in the bucket of an elevating work platform (EWP)
- any hand tools or other equipment held by any person involved with the operation or
- the load being moved or material being handled is within the exclusion zone.

The exclusion zones for operating plant operating near electric lines, are listed in Table 5.1.

Table 5.1 Operating cranes and plant near overhead electric lines

Nominal phase to phase voltage (kV) (Exposed unless otherwise specified)	Untrained person operating plant* (mm)	Authorised person or instructed person operating plant*, with safety observer	
		Un-insulated portion (mm)	Insulated portion (mm)
Insulated low voltage with consultation & Insulation verified	1000	-	Contact allowable
Low voltage (LV) with consultation	3000	1000	Contact allowable
Low voltage (LV) without consultation			
> LV & up to 33 with consultation		1200	700
> LV & up to 33 without consultation			
> 33 & up to 50		1300	750
> 50 & up to 66		1400	1000
> 66 & up to 110		1800	
> 110 & up to 132			
> 132 & up to 220		6000	2400
> 220 & up to 275	3000		
> 275 & up to 330	3700		
> 330 & up to 400	8000	4000	
> 400 & up to 500		4600	

Nominal Pole to Earth dc Voltage (kV)			
+/- 25	3000	1200	700
+/- 85		1800	1000
+/- 150			
+/- 270	6000	2400	
+/- 350		3200	
+/- 400		3600	

*Operating plant includes fixed location cranes (e.g. tower cranes)

Table 5.1 Exclusion zone for operating plant operating near electric lines (extract from [Appendix B](#)).

If you are unsure of the voltage of overhead power lines, remain at least 8 metres away.

Figure 3.1: Examples of electric power towers and voltages

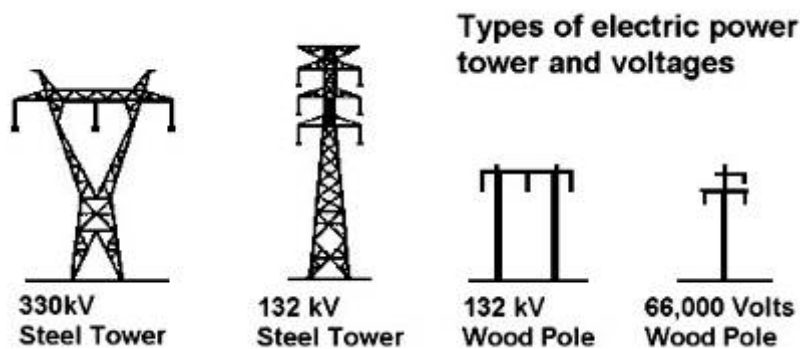

Planning for work on a suspended floor of a building

If the EWP will need to operate on a suspended floor, before you undertake the work you must make sure, as part of your operational planning processes, that:

- The floor can support the weight of the EWP. This may require an assessment by a qualified engineer.
- The EWP will be positioned on the floor in accordance with the engineer's instructions.
- Other people working in the area will be avoided.
- The area of the working radius of the machine will be fenced and barricaded.
- Props or other forms of support will only be used if this is in accordance with the engineer's specifications.
- A safe work method statement is prepared, if this is required.

Planning for the use of solvents or chemicals on the work platform

This is another issue requiring pre-operational planning.

If the tasks to be performed using the EWP involve the use of hazardous substances such as solvents or other chemicals, your operational plan needs to incorporate special precautions.

The following operational procedures need to be observed:

- Avoid having different classes of hazardous substances in the basket at the same time.
- Make sure material safety data sheets (MSDS) are provided for all the substances that will be used. Suppliers have a legal obligation to provide an MSDS when they supply any of these substances. Each MSDS outlines the control measures that must be applied for that substance.
- Make sure you and other personnel always wear appropriate personal protective equipment.
- Make sure the work starts at the closest point to any adjoining buildings and moves away from buildings.
- Make sure the solvents or chemicals do not enter windows or the intake registers of building air-conditioning systems.
- Make sure barriers are placed around the planned EWP working radius.

Never mix chemicals in the basket.

Planning for work above staff facilities

If the EWP will be operating above facilities such as work areas, lunch rooms and washrooms special precautions will be required, because you will be working near people.

Your operational plan must:

- identify any specific hazards such as eating areas and wash rooms where a constant movement of people can be expected
- ensure a safe work method statement will be developed, outlining the work procedures
- ensure workers on the site will be informed of the work schedule
- Make sure the area beneath the platform will be barricaded, marked with warning signs and kept clear of people
- ensure all tools and equipment on the platform will be secured, and
- ensure overhead protection of the facilities is provided, beneath the platform of the EWP, if necessary.

Planning emergency procedures

Before starting any work you must be sure your operational plan includes procedures for responding to emergencies.

This is to make sure you know what to do, and what sequence to do it in, should an emergency arise.

The types of situations you need to consider are described under 'emergency procedures' in Chapter 4.

In addition, you must be aware of any site-specific emergency procedures for the work area.

Workplace consultation

Consultation with other people at the work site and anyone else who may be involved or affected by the work you do is essential, because it:

- informs these people about what will be happening
- allows them to alert you to any particular hazards or other problems, and
- informs you about their work, allowing the work program to be properly organised and coordinated.

The people and groups with whom you will need to consult when you are planning your work have already been described in the discussion of job requirements, workplace rules, hazards and control measures above.

Refer back to these sections to make sure you know who needs to be involved in the consultation process.

Conducting routine equipment checks before setting up the EWP

Once you have determined that the EWP can operate safely on the site and have agreed to undertake the work, it is time to check the machine to make sure it is in good working order.

These pre-operational checks are essential, and must be carried out before you set up the machine at the site and before any work commences.

The main purpose of checking the equipment is to identify any defects.

If a defect which might affect the operation of the machine is found, the machine must be secured against operation, the defect must be tagged and you must report the defect to your supervisor or the person in charge of the operation. The tag should clearly note that the machine is out of order and is not to be used.

The pre-operational checks must be conducted in accordance with the manufacturer's specifications, which you will find in the service log book.

So the first thing you need to do is check the log book. Every elevating work platform will have a log book.

The log book provides three important sets of information for the operator:

- records of regular service checks
- a pre-operational checklist and
- records of any faults or defects.

It is important to check each section of the log book, and in particular the service records, to make sure that all aspects of the pre-operational checks have been covered and that regular servicing, maintenance and repairs have been undertaken.

If a service is overdue, inform the owner of the machine and do not use the machine.

In addition to checking for defects, you must check the safe working load (SWL) of the EWP (i.e. the maximum weight that can be safely supported in the basket).

This is important, because the major function of any EWP is to safely elevate personnel and materials.

The SWL will be shown in the EWP's operating instructions manual, and must also be clearly marked in the platform.

You must then estimate the total weight of all the materials and personnel to be carried, including all protective equipment, and make sure that the SWL will not be exceeded.

If the SWL were exceeded there could be a structural failure to the boom or the machine could tip over.

Routine pre-set-up equipment checklist

The pre-operational checks which you need to undertake on the machine include, but are not limited to, the following:

These are the things you must check	This is what you should look for	This is what to do if something is wrong
All load-bearing parts	The load-bearing parts of the EWP are found along the boom arm of the EWP. Check that all parts are in good condition and are not bent, distorted or fractured. . If the boom is insulated, check that it is in test and that the insulation is not compromised by foreign matter.	Report any damaged load-bearing sections to your employer or the person in control of the EWP. The machine must not be operated and must be shut down with appropriate signs to make sure others will not operate it.
Operating instructions and log book	Locate the operating instructions/service manual and log book. Make sure the log book has been completed and is up to date and all service requirements have been met.	If a service is overdue, inform the owner of the machine and do not use the machine.
Emergency descent equipment	Check the work platform. Make sure the emergency descent equipment is secure and the safety release clips are in place, have not been tampered with and can be removed by hand. Also check that warning signs are in place and have not been tampered with.	Correct any defects before commencing work.
Ground controls	Check the ground-level operating controls to make sure they are free of damage. Operate and become familiar with each function, so that you will be able to instruct someone to lower you down in an emergency. Locate the emergency lowering control and make sure it is able to be operated with ease.	If the ground controls are damaged or appear to be not operational, report the defect(s) to your supervisor.

These are the things you must check	This is what you should look for	This is what to do if something is wrong
Handbrake	Check that the handbrake is able to be engaged, to add to the stability of the machine during lift operations.	Correct any defects before commencing work.
Hydraulic fluids	Check that the hydraulic oil is $\frac{3}{4}$ full, or up to the full mark on the dipstick or view glass level. Check for leaks.	If the hydraulic oil is low or leaks are detected, report this to your supervisor. Top up the hydraulic oil in accordance with the manufacturer's specifications, or arrange for maintenance and repairs if more serious problems are detected. . Use only correct insulating oil if it is an insulated EWP.
Hydraulic hoses and fittings	Check that all hoses are securely attached and in good condition, without any signs of damage. Leaking oil on hydraulic pipes is a sign of damaged or broken hoses.	Report damaged hydraulic hoses to your employer or the person in control of the EWP. The machine must not be operated and must be shut down with appropriate signs to make sure others will not operate it.
Lubrication	Check that all relevant parts are greased and lubricated. Refer to the maintenance schedule and note greasing requirements.	If a service is overdue, inform the owner of the machine and do not use the machine.
Motor engine oil, radiator and battery	Check that the engine oil level is within the limits prescribed in the operator's manual and that radiator and battery fluids are at the correct levels.	When you have been instructed how to do it, add engine oil and/or other fluids as necessary, in accordance with the operator's manual.
Oil leaks	Check under the EWP for oil leaks. The ground area should be free of oil.	If oil is leaking from the engine area of the EWP, report this to your employer or the person in control of the EWP prior to operation. The risk will need to be assessed.
Outriggers/ stabilisers are operational	Raise the outriggers to make sure they are in good working order and free of damage or leaks.	If the outriggers are not operating correctly, report this to your employer or the person in control of the EWP. The machine must not be operated and must be shut down with appropriate signs to make sure others will not operate it.

These are the things you must check	This is what you should look for	This is what to do if something is wrong
Platform/basket	<p>Check that:</p> <p>The platform is clear and free of damage or obstructions.</p> <p>The operating controls are clearly marked and free of damage.</p> <p>The Safe Working Load sign is clearly visible.</p> <p>All safety warnings signs are in place and clearly legible.</p> <p>The platform mounting pins are secure and in good condition.</p> <p>The handrails are secure and not bent or damaged.</p> <p>The door opens and closes correctly.</p> <p>The gate catch shuts and catches.</p> <p>The safety harness anchor points are in place and undamaged.</p>	Report any damage to your supervisor. Do not operate the EWP if the platform and/or its operating controls are damaged.
Safety harnesses	Check that safety harnesses are attached to the work platform for each person who is to be elevated.	Obtain and secure appropriate safety harnesses.
Power Take Off (PTO) control	The PTO needs to be in the neutral position to avoid inadvertent elevation of the machine when the engine is started.	Place the PTO in the neutral position. Do not drive the machine with the PTO engaged, as serious damage will result.
Specification plate	<p>Check the specification plate for:</p> <p>the manufacturer's name, year of manufacture, model and serial number;</p> <p>the EWP's SWL ;</p> <p>cautions and restrictions on operations;</p> <p>operating instruction plate adjacent to the controls;</p> <p>supply voltage ratings ;</p> <p>the weight of the EWP;</p> <p>an electrical hazards warning label;</p> <p>the EWP's wind speed capability.</p>	If the specification plate is missing or cannot be read, the machine must not be used.

These are the things you must check	This is what you should look for	This is what to do if something is wrong
Support gussets at knuckle joints	Check the knuckle joints for signs of wear or damage. Flaking paint or distortion of the knuckle are a sign of overstressing of the boom as a result of overloading, and indicate potential damage.	Report knuckle damage to your employer or the person in control of the EWP. The EWP must not be operated if the support gussets show signs of damage. It must be tagged to indicate that it is faulty and to ensure others will not use it.
Tyres	Check that the tyres are in good condition, free of cuts or divots. Check the tyre pressures against the manufacturer's specifications (be aware that most boom and scissors EWPs have foam-filled (solid rubber) tyres).	Worn or damaged tyres need to be replaced. Adjust tyre pressures in accordance with the pressure requirements shown in the operator's manual.

A simple reminder

The following figure provides an overview of the things that need to be checked during a pre-operational inspection of a trailer-mounted elevating work platform.

You can use it to see whether you know what to check and why you need to carry out these checks.

Figure 3.2: Pre-operational checks on a trailer-mounted EWP

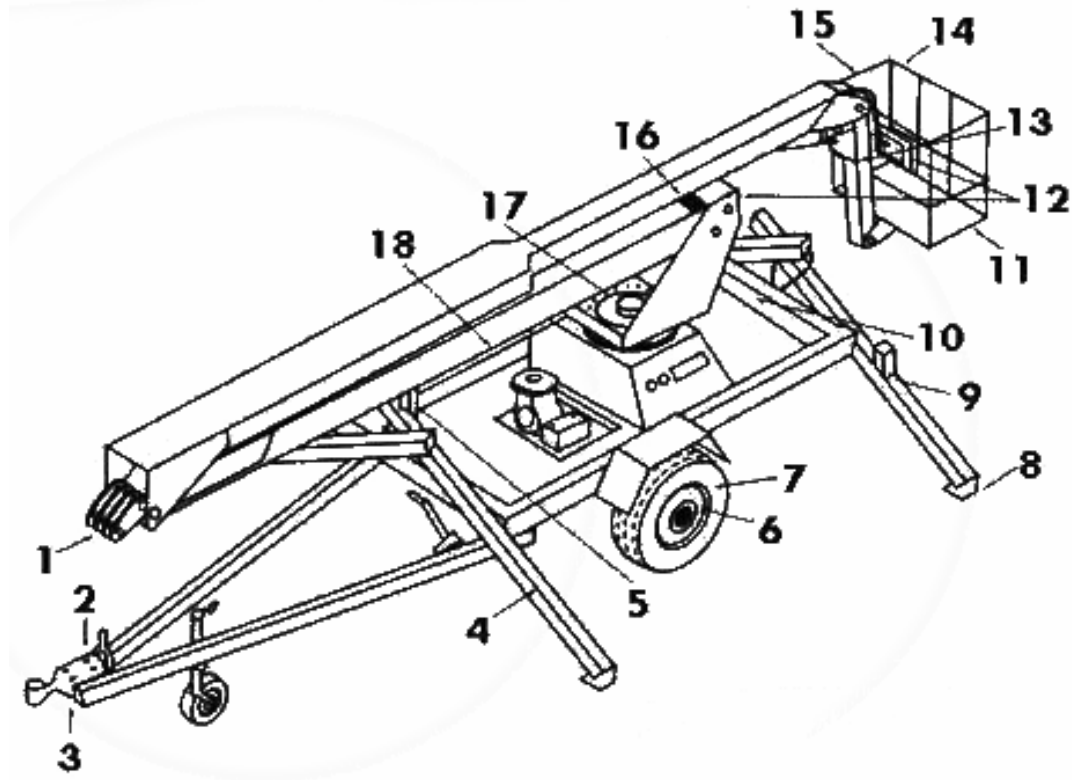

1. Check for damaged plates.
2. Check parking brake operation.
3. Check for loose or missing bolts before towing.
4. Check that the leg/boom interlock switches are fitted and working.
5. Check the boom support bracket for cracks, and ensure the travel pin is fitted before towing.
6. Check for loose or missing nuts before towing.
7. Check tyre condition before towing.
8. Ensure legs are down before use.
9. Check for cracks.
10. Ensure tie-down strap is fitted and used before towing.
11. Check the basket frame for cracks and check the basket for cracks at the mounting bolts.
12. Check that the control handles return to the neutral position.
13. Check flyboom restraining kit.
14. Check that the harness and safety anchor points are in good condition.
15. Check basket for excess tilting.
16. Check that the boom rest is not squashed or cracked.
17. Check for loose or missing bolts.
18. Check for straight level rods.

Setting up the EWP

Once you have inspected the site, identified its hazards, satisfied yourself that the site is suitable and completed your pre-operational checks on the EWP, you are ready to set up the machine so you can begin the work.

The set-up procedure involves quite a number of steps. You must be familiar with all of these steps and be competent in performing them.

If it is some time since you carried out your site inspection, you will need to do a final check of the work site, before you start to set up the machine, to make sure there have been no changes since your first inspection.

The starting point is to decide where you will set up the machine.

This area should be flat and able to stand the weight of the machine. If it is not flat, or if it has a soft base or has been backfilled etc, you will need to make sure you have the required ground cover, such as steel plates and/or sleepers, to control the hazards associated with loose or unstable ground.

The set up procedure then involves the following tasks:

- Notify the relevant people (site foreman, safety officer, etc) of your arrival and intentions, discuss your work program with them and seek their advice.
- Check the environmental conditions, including the wind speed, to ensure they are within the manufacturer's specifications.
- Set the EWP up as close as possible to the work that you are required to do, in such a way that it will fully meet your requirements but at the same time create the least possible disturbance to others working close by. An observer may be needed to assist you in positioning the EWP. Make sure the EWP will not be on a slope that exceeds the manufacturer's recommendations.
- Firmly apply the parking brake and place the transmission in neutral (or in accordance with the manufacturer's recommendations).
- Place all the required traffic control displays and warning devices. Warning signs at the front and rear should be placed at least 50 metres, but not more than 150 metres, from the vehicle.
- Ensure any necessary barricades or road marker cones are placed along the side of the vehicle. Road marker cones should be arranged to keep traffic clear of the area where the elbow of the boom will be operating.
- Set the rotating flashing lights in motion.
- If the EWP does not have outriggers/stabilisers, chock one pair of its wheels, by firmly placing suitable obstructions against each wheel to prevent the machine from moving in any direction.
- If the EWP has outriggers, chock the front wheels and set the outriggers onto a firm surface or the appropriate packing. Make sure the area is clear of personnel before lowering the outriggers/stabilisers. The outriggers need to be fully extended, unless they are also being used to level the machine. Never reset the outriggers while the machine is elevated, because this can cause major instability and allow the machine to overturn. Remember to avoid soft ground, sloping surfaces or other conditions that may affect the stability of the unit.
- If the EWP is being set up on a sloping surface, position the outriggers/stabilisers on the lower sloping side first, again making sure the area is clear of personnel before lowering the outriggers/stabilisers. This will allow you to level the platform and then engage the remaining stabilisers.

-
- Check that all the necessary safety harnesses and lanyards are on the machine and that they comply with the relevant standards and are in good working order. Re-check the anchor points for the lanyards, ensuring they are sound and not bent or broken. Check that the lanyards are the correct length for their anchor point(s) on the machine.
 - Check the personal protective equipment (PPE) needs for the job and make sure all the necessary PPE is available and in good condition.
 - Fully engaged the EWP's spring lockouts, if these are provided.
 - Undo any basket and/or boom tie-down straps, to allow free movement of the basket.
 - Make sure all personnel are clear of the basket and boom while the basket is being lowered to the entry position.

Starting up the EWP and making sure everything is working properly

Once you have completed all pre-operational checks and you have set the EWP up for work, it is time to start up the machine and conduct further checks to make sure that all the controls and movements of the machine are functioning correctly, before commencing work.

These final checks are an important part of making sure the work can be conducted safely.

Your supervisor or trainer will take you through each of the things that you need to check.

Remember that you must locate and read the operations manual before you carry out these start-up checks.

Ground compartment checks

To commence your start-up checks, open the ground compartment, turn the select switch to 'ground' and start the motor.

Operate each of the ground control levers in turn, to make sure you know what it does and it is operating properly. You need to do the following:

- Lift and lower the boom. Note that some machines have emergency lowering taps, which allow the machine to lower to the folded position at a controlled speed. If these taps are fitted, raise the machine slightly and open the taps to allow the machine to lower again. This will ensure you know where the lowering valves are located and that they are operational.
- Slew the boom to the left and right, making sure there are no potential hazards in performing this function. If the boom cannot be slewed, check that the slew locking pin has been removed.
- Telescope the boom out to the range required for the tasks to be undertaken and back again.
- Check the auxiliary power unit on diesel and gas machines. This is important because if you run out of fuel for the primary unit or the motor fails, you will be relying on the auxiliary power unit to supply the power required for the vital functions that will allow you to descend.
- If the machine does not have an auxiliary power unit or emergency lowering valves (taps), refer to the operator's manual for instruction on how to lower the machine in the event of an emergency.

Check the emergency lowering system before elevating

The ground controls must not to be used while personnel are working in the basket.

They should be used **only** for:

- checking the machine's operation before using the machine
- carrying out maintenance on the machine, or
- emergency purposes (e.g. lowering the basket).

Checks from the platform

Once you have completed your checks at the ground compartment, it is time to test the operational performance of the machine from the basket or platform. You need to:

- turn the select switch to platform/basket
- attach your harness and put on your hard hat (safety helmet), rubber-soled steel cap shoes and other PPE as required. (The first two items of safety equipment need to be worn by all personnel using the work platform)
- make sure the self-closing action of the platform gate is working
- test the dead man switch to make sure it is functional
- test the automatic levelling device
- check all alarm systems
- confirm the 'Safe Working Load at Driving' positions, and
- test each of the control levers in the basket to make sure all operations are functioning correctly and smoothly.

Chapter 4: Operation of the elevating work platform

Introduction

Once your supervisor is satisfied you have completed all the pre-operational checks of the machine, it is time to start using the machine to perform the necessary work.

This will involve elevation of the basket/platform, telescoping of the boom and slewing of the boom.

Your supervisor will take you through each of these stages, in accordance with the plan of work that you have previously completed.

Key learning areas

The main things you will learn in this chapter are:

Planning and conducting an elevation

You will learn about assessing the task's requirements, planning how you will conduct the elevation and raising and positioning the platform to carry out the job.

Moving the EWP

You will learn how to safely move the EWP to a new position.

Operational issues and emergency procedures

You will learn how to respond to issues that can arise during the operation of the EWP, including emergencies.

Preparing for an elevation

- Conduct a final assessment of the task's requirements: the job to be done, the operating radius of the boom and any workplace hazards that need to be considered.
- Make sure all relevant site personnel have been consulted and are familiar with your plan of work.
- Make sure the site is clear of people.
- Make sure your work plan has identified all potential hazards and includes appropriate control procedures.
- Make sure all tools and gear required for the job, in accordance with the job plan, are placed in the tool tray of the basket and will not hinder the opening of the platform gate, which will be the primary escape route if there is an emergency.

Conducting an elevation

- Check the fit of your safety harness. Check that the lanyard length is correct for the type of harness and the attaching points. Clip the harness lanyard to the anchor point. Never clip the harness lanyard around the safety rail. Make sure other personnel working in the basket have also fitted and properly secured their safety harnesses.
- Check that small items such as nuts and bolts cannot get under the foot switch, as this would stop it operating.
- Look up and around. Make sure there are no overhead obstructions or power-lines that might have been overlooked. Remember, 'look up and live'.
- Moving the basket and / or boom of the EWP during operation may introduce or create new hazards, e.g. greater proximity to power-lines. The EWP must be carefully monitored to ensure that its basket and boom are travelling in the direction intended.
- Commence the elevation by shifting the control lever. Do not operate the lift at a high speed, especially if you are in a confined area. Keep in mind that most machines will only move in creep mode after a predetermined height has been reached. The speed of lifting, lowering, slewing and telescoping are set by a speed controller on the dash panel.
- Elevate the EWP to the full extension required, provided it is safe to do so.
- Slew the boom, where fitted, to make sure that this function operates smoothly.
- In confined areas, always work in the slow mode.
- When you release a control lever there will be a delay of a few seconds before the relevant function stops. This is called the 'ramp', and it allows the function to slow down to a stop, rather than jerk to a halt. This is most obvious during slewing operations, when jerking the machine to a halt could make it unstable.
- However, if there is an emergency in any situation you must release the dead man switch, and the function will then come to an immediate stop.

Moving the EWP

Moving (or 'mobiling') an EWP requires special care, because of the greater risk of destabilising the machine.

Never move an EWP with its outriggers extended.

The following safety measures need to be applied when moving an EWP:

- Wherever possible, retract the boom section(s) of the machine and lower the basket.
- You must be wearing your harness and have it attached to the anchor point.
- Make sure the boom section is in line with the chassis and the basket is behind the drive wheels. This ensures the controls will function in the correct way.
- Check that the turntable/basket lock is engaged.
- Make sure the path you are going to travel is clear of obstructions that might hinder a smooth passage.
- Watch out for people at ground level and make sure the travel area is free of pedestrians.
- Make sure that all warning devices are operating.
- Make sure the tyres are inflated to the correct pressure.
- Make all of your steering movements smoothly.
- Be constantly alert for pot holes, obstructions, people, other machinery and any other hazards.

-
- If you are moving a boom EWP on uneven surfaces, retract the boom fully and face it in the direction of travel. Look for the FWD (forward) arrow on the chassis of the machine to find out which way is 'forward' for the machine. To start the machine moving in its forward direction, move the control lever on the control panel to the forward position. If the machine starts moving in the reverse direction, the boom has been placed 180 degrees (or half a turn) from its normal position.
 - If you are moving an EWP up or down a hill, always travel with the platform pointing up the hill.
 - If you are travelling some distance, always have the boom fully retracted and as close as possible to the ground without the basket scraping. High range speed can be selected for these movements, provided the ground surface is even and free of obstructions.
 - While travelling in open areas using the high speed function, do not release the drive lever quickly or sharply switch directions (forward to reverse).
 - If you are travelling in a confined area, do not use the high speed function and allow a safe distance for stopping.
 - If you have to move an EWP with an elevated platform:
 - make sure that the tools, equipment and personnel do not exceed the SWL of the machine, and keep all tools in a tool bag away from the door
 - be constantly aware of overhead obstructions such as power-lines, services, people, surrounding structures and other machinery
 - travel at creep speed with the utmost caution, staying alert to make sure the surface is flat with no gradients or speed humps etc
 - maintain a good look out for ground conditions such as potholes, soft, unstable or rough surfaces and anything that will make the machine unstable.
 - never travel over rough or uneven ground
 - if the ground surface has pot holes or is uneven, lower the machine to increase its stability
 - if the machine is truck mounted, check that the tyres are inflated to the correct pressure
 - do not move an elevated EWP across the slope of a hill unless the slope is extremely gentle (only 1 or 2 degrees), and
 - the dead man switch (foot switch) is a safety device and should only be used if the control levers fail to stop the machine or in other emergencies. If there is an emergency, release the foot switch and the machine will come to an immediate (and very abrupt) stop.

After moving the EWP

- Check all the gauges, lights and switches to make sure they are functioning correctly.
- Check the emergency stop controls.
- Check the emergency lowering systems (tap, lever, press button, etc) to make sure they are still operational and have not seized or been broken. and
- Before trying to elevate a trailer or truck-mounted EWP, make sure the cradle pin or basket strap has been removed.

Other operational issues

- Do not climb out of the machine while it is elevated, except in an emergency.
- Do not carry loads on the hand rails unless this is specified by the manufacturer.
- Do not stand on the hand rails. You must stand with both feet firmly on the platform floor.
- Do not use the machine as the earth lead for an electric welder! This can cause serious damage to the machine and may result in a major malfunction.

-
- Do not put a bolt or wedge on the dead man switch to keep it pressed. This foot switch is a safety device which is there for your protection, so do not abuse it. Some foot switches now have a time delay built in, to prevent interference with their proper operation.
 - If movements do not stop when the controller is brought to neutral, and the only way you can stop the motion is to release the foot switch, there has been a major malfunction with the platform controller.
 - **Do not** think that there may simply be something caught in the workings of the lever and jiggle the lever back and forth to clear the problem. If you do this, the controller may fail completely and cause the machine to react violently, resulting in serious injury or death.
 - Instead, hit the red button (emergency stop) immediately to disable the machine, and have someone on the ground switch the machine to its ground controls and bring you down or lower you using the emergency lowering tap or valve.
 - If you are working with an EWP on an upper floor of a multi-storey building, make sure the floor can stand the weight of the machine by checking with the site engineer, who will usually require a work method statement (see Chapter 3). Make sure your work area is bunted off to prevent other machines coming into your work area and effectively doubling the weight carried by a small floor area.
 - Be wary of darkened areas and fading daylight. If this happens, stop work and get sufficient portable lighting over the whole working area.
 - Watch out for changing weather conditions, and especially wind, storms and lightning.
 - If you are working at height and the motor of the machine stops and cannot be restarted, call someone at ground level to lower you down. During your start-up checks you would have found out how to lower the machine in an emergency (see Chapter 3). Now you can instruct the person on the ground how to lower you down. If this is not possible, you may lower the platform by using the backup battery or the bleed down valves (see under 'emergency procedures' below). As a last resort you can use the emergency descent device (if the EWP is a truck-mounted machine), again as described under 'emergency procedures' below.
 - If you are working at height and the platform/basket drops slightly for no apparent reason, the machine has developed a fault. Stop work immediately, lower the basket to the ground and have the machine repaired or replaced. It is quite possible that the machine has hit power-lines recently and has not had the hydraulic cylinders checked for internal arcing, which can cut the 'O' rings and thus cause the machine to suddenly drop.
 - If the EWP begins to subside into the ground, despite 'pig sty' packing, you should seek assistance from a competent person about the ground conditions, relocate the EWP if possible and/or relocate the pig sty packing to give a greater area of load distribution. If you experience an event like this you might have failed to properly identify or assess site hazards such as unstable ground or backfilled trenches, or you might not have used adequate packing under the outriggers/stabilisers to distribute the load over a larger area.
 - If the rubber tyres of a truck-mounted EWP without outriggers/stabilisers start sinking into the ground, the operation should be stopped, the boom must be retracted and lowered and further assistance must be sought.

Emergency procedures

Contact with powerlines

If you come into contact with powerlines, despite the precautions discussed in Chapter 3, you should:

- Stay calm.
- Do not climb out of the machine, as it may be 'live'.
- Warn others to keep clear.
- Try to move the machine away from the powerlines, if possible, to break the contact with the lines. If you manage to do this, come down immediately, have the machine checked over by the owner for arcing and other damage and call the power authority so they can check the lines for damage.
- If you cannot break clear of the powerlines and you are using a truck-mounted EWP with an abseiling or emergency descent device (EDD) mounted on the outside of the basket, descend from the basket using this device (for more details, see below). For other personnel in the vehicle cabin or on the vehicle tray, there is generally no reason to alight from the vehicle. Assign a lookout to warn others to stay clear.
- If there is a danger of fire, or if you are alone, jump clear from the machine onto dry ground and move away from the machine. Do not step down.
- Stay near the machine until help arrives.
- Have someone notify the site manager/supervisor, who should call the relevant authorities immediately.

Collapse of personnel in the basket

If you are on the ground and your workmate up in the basket appears to have fainted and has slumped down inside the basket, you should:

- Try to make contact with the person (yell out to them or call their mobile phone)
- If you get no response, call for first aid or ask someone else to go for first aid assistance and
- Check for hazards in or around the work area, such as power-lines, dangerous substances or materials that might have caused asphyxiation.
 - If no hazards are found and the machine is safe, switch it to ground controls and lower the person down.
 - If there is an electrical hazard, **do not touch the machine**. Call the power authority to have the power supply shut down and the problem rectified.

If the EWP starts to tilt to one side

- Stop work immediately and lower the platform to the ground.
- Get out of the platform, alight from the machine and check out why there is a lean (e.g. packing sinking into a soft or unstable ground surface, or an outrigger hydraulic ram slowly leaking internally).
- If you are not sure, get the advice from a competent person before any attempt is made to elevate the platform again.

In most cases you will need to relocate the EWP to stable ground.

If the motor cuts out

If the motor of the EWP cuts out the platform must be lowered to the ground. This can be done by:

- calling out to an operator at ground level to engage the ground controls and lower the basket
- bleeding the valves of the hydraulic arms
- using the Emergency Descent Device, if one is fitted (see below) or
- using the hydraulic accumulator (for truck-mounted machines)

As discussed in Chapter 3, you need to understand, before you start work, how to lower your platform should the motor cut out.

Emergency Descent Device procedures

Many EWP's are fitted with emergency descent devices (EDDs) for emergency evacuations from the bucket or the work platform.

The first thing to do in an emergency situation (such as the failure of the controls at height) is to call out to an assistant to lower the basket using the ground controls.

If it is not possible to safely lower the basket to the ground, you may need to activate the EDD.

These descent devices vary from one EWP to another, so you should be trained in the EDD procedures that apply for the particular machine(s) you will be operating, and you need to check the supplier's requirements in relation to the EDD.

As a general rule, however, the following procedures will apply:

- Release the EDD safety release clip.
- Press the securing pin to release the EDD.
- Make sure there is no-one beneath the boom, and particularly the basket, before activating the EDD.
- Attach the EDD to the 'D ring' on your safety harness.
- Disconnect the safety strap from the safety harness and climb to the outside of the basket.
- Use one hand to hold the rope just below the EDD and the other hand to hold onto the basket, while slowly transferring your weight to the EDD.
- Release your foothold from the basket and transfer your hand from the basket to the rope above the EDD.
- Increase or decrease your speed of descent by changing the angle at which the tail of the rope is fed into the EDD. To gain the maximum braking effect, use your hand that is holding the tail of the rope (i.e. below the EDD) to hold the rope up, and then allow the rope to run slowly through your hands as you lower yourself to the ground.
- The descent of a person escaping via the EDD can also be slowed if an assistant on the ground gently pulls on the rope.

Chapter 5: Shutting down the equipment and securing the site

Introduction

This chapter deals with the things that you need to do when you have completed your work with the EWP.

It is important to make sure that after you have left an EWP it is not dangerous to other people, either because of where it is left or because of the condition you left it in.

The following procedures are just as important as operating the machine. Make sure you follow each stage carefully, and make sure you know the reasons for proper shut-down procedures.

Key learning areas

The main things you will learn in this chapter are:

Shutting down the equipment

You will learn the proper shut-down procedures and post-operational safety checks.

Securing the site

You will learn how to ensure the site area is clear and safe at all times.

Shutting down the equipment

Lowering the machine

Before you lower the machine you should look around and under the basket to make sure the area is clear of people, obstructions and any other hazards.

If people are present, sound the horn to get their attention and indicate to them that the machine will be lowering.

While people not using the EWP should not be under or close to the machine, and should be kept away with barricades etc, members of your own work team may be close to the machine, so care is required.

Lower the boom slowly and carefully.

Stowing the machine

Once the platform is lowered, drive the machine to its designated parking area, place it in a safe position, lower it fully and turn everything off.

Remove your harness, stow it in a safe, dry place, dismount from the machine, remove your tools and equipment from the basket and lock control panel doors.

Shut down the motor and (if required) isolate the fuel supply.

Place the machine on charge, if required, or fill it with fuel in accordance with your supervisor's directions. Leave the oil and coolant checks until the following day, to prevent oil burns or water scolding.

Lowering and stowing procedures for truck and trailer-mounted EWPs

If the EWP is a truck or trailer-mounted machine, the sequence of events in shutting down and stowing the machine is slightly different. The following procedures must be observed:

- After checking to make sure there are no hazards below, line the boom up with the chassis and lower the bottom boom arm into the cradle. Then lower the top boom onto the bottom boom.
- Remove your safety harness, stow it in the cylinder provided in the corner of the basket and refit the lid onto the cylinder.
- Disembark from the basket and gather and stow your tools.
- Raise the outriggers and pin them (where required).
- Gather up any packing materials and place them in the designated area.
- Install the boom locking pin or strap.
- Turn off the motor or (for a truck-mounted machine) disengage the power take off (PTO).

Remove the keys from the EWP, lock the ground control cabinet and make sure the keys are stored in a safe place.

Securing and stowing outriggers

The securing and stowing of outriggers require special attention. You should work through the following procedures with your supervisor:

- retract the outrigger footplates
- retract the outrigger beams
- if applicable, lock in the outriggers with the correct pins
- clean the steel plates, and

-
- place 'pig sty' packing either on the carrier or in a designated storage area which will be available for future access.

Post-operational safety checks

Check the machine for breakages, other damage or leaks. More specifically, you need to check:

- all the hydraulic arms, to make sure they have not been damaged or bent during the machine's operation
- the boom, for dents or cracks in its welds and joints
- the slew ring, for any bending or other damage
- the basket, to make sure it is in good working order and has not been damaged
- the outriggers/stabilisers, to make sure they are in good order and
- all safety devices, to make sure that they are intact and operational.

Report any faults or damage to your supervisor/employer immediately, make sure they are noted in the log for corrective action and, where necessary, make sure warning tags are attached to the machine.

Securing the site

Secure the machine against unauthorised use, either by chaining the machine to a post or girder or by removing the platform control panel (as is possible with some machines) and locking it in a safe place.

Most construction sites are fenced, with the gates being locked after hours. However, leaving a machine in a mall or shopping centre car park overnight is always a high risk. Instead, try to leave it inside the shopping centre buildings, if possible, or fence the machine off with a temporary fence that can be locked.

Chapter 6: Getting a certificate of competency

Introduction

Now that you have gained at least some of the knowledge and skills required to safely operate an EWP, it is time to discuss how you go about getting a licence.

A licence to operate an elevated work platform (EWP) is an important qualification. It is a statement, for yourself and your employer, **that you have achieved the minimum level of competence required to operate this item of plant.**

It is also important to remember, however, that even though you may need to have a licence to operate an EWP, **the *licence* issued by the OHS authority does not mean you can safely operate every EWP.**

Your employer must also make sure you are provided with all necessary information, instruction, training and supervision before you start any independent work using an EWP.

Your employer must also provide training and instruction whenever you are required to use equipment or attachments that you are not familiar with and whenever new work processes are introduced.

How to become a qualified EWP operator

You must be trained.

It is essential for all operators of an EWP to be suitably trained.

If you **do not** hold a qualification to operate an EWP, you must not attempt to operate this equipment without being supervised and instructed in its use.

In most States and Territories **you must be 18 years of age** before you can obtain a licence to operate an EWP.

Training is provided by a Registered Training Organisation (RTO) who is registered to deliver this type of training and assessing and can be delivered in a number of ways: through '*on-the-job*' training, through an '*off-the-job*' training or a combination of both.

In '*on-the-job*' training, the person being trained has access to an EWP as part of their work duties and receives instruction and direction from a supervisor who holds a current licence on the use of the EWP as part of their work program.

'*Off-the-job*' training is undertaken at an RTO who is registered to deliver this training for this high risk plant through an approved formal training program. Training can be delivered off the job, on the job or a combination of all.

In all situations, the training **must be** supervised.

The occupational health and safety (OHS) agency (see Appendix C) or the State Training Authority in your state or territory can advise you about accredited training organisations providing this type of training.

It is a good idea to keep your **training record/logbook** as this documented record of training and experience as this evidence may assist you in gaining employment.

Each entry in the logbook must be signed by a licensed person supervising the work.

A properly maintained training logbook is used by the RTO as evidence of your on the job training component of your training and confirms you are ready to be assessed for a certificate of attainment.

You should check with your local certifying authority about the requirements for trainees to maintain a training record/logbook.

You **must be** supervised while you are being trained.

Regardless of where you are being trained, you must be **directly supervised by a licensed supervisor**.

Supervision is '**direct**' if the person supervising your training is in a position to intervene immediately if there is an emergency or a hazardous situation beyond your control.

A trainee must be **under direct supervision** at all times **unless** the supervisor judges that the level of competence achieved by the trainee means direct supervision is no longer warranted; and the circumstances of a particular task make direct supervision impractical or unnecessary.

This is another good reason to keep a *training record/logbook*: it can help your supervisor decide when direct supervision is no longer necessary.

What you need to know and show

You need to satisfy your supervisor that you can complete tasks and perform your work safely without the need for direct supervision.

You will need to show you can successfully:

- check and secure the equipment and the work area (see Chapter 3)
- lift, shift and place loads (Chapter 4), and
- shut down the equipment and secure the site (Chapter 5).

When you can do carry out these functions in a competent manner, you are ready to be assessed by an authorised assessor approved by the OHS authority.

You must be assessed

When your supervisor or trainer is satisfied you can do everything required to operate an EWP safely, it is time to be assessed.

This means you need to do an assessment, (*answer the theory questions*) in order to independently determine whether you have the 'competencies' (*knowledge and skills*) required and ready for the practical test (hands on assessment).

The assessment is in two parts.

The *first part* will test your **knowledge** about the machine and safe work practices associated with its use. This part can be a written test or an oral test.

The *second part* of the assessment tests your **performance** in operating the EWP. This part requires you to demonstrate to an assessor that you can operate the EWP safely and competently e.g. ask you to **perform** a range of tasks with the EWP.

Contacting an RTO for assessment

RTOs are required to conduct their assessments in accordance with the OHS legislation in the relevant state or territory and guidelines issued by the certifying authority.

The OHS agency in your state or territory (listed in Appendix C) can provide a list of authorised RTOs.

If the assessment is being carried out to determine whether you meet the requirements for a licence (as is the case in almost all states and territories), the assessor will require you to:

- truthfully complete an application for assessment
- show evidence of your identity (such as a driver's licence or passport)
- show evidence that you are at least 18 years old, and
- show documentary evidence of any relevant experience, previous assessments, training, certificates or qualifications.

The assessment

The RTOs will ask you for your identification and proof of age, along with training records and your logbook. You will also have to complete the necessary paperwork, including your application for assessment.

This *first part* of the assessment is usually a written test, but if you prefer it can be an oral test, with the assessor asking you the questions and recording your responses.

Your level of English will need to be sufficient to understand and follow the instructions of the assessor. Interpreters **cannot** be used during the assessment process.

A EWP in good working order must be available for this part of the assessment.

You must show that you can perform these tasks competently and safely.

After your assessment

After the assessment, the assessor will give you a document that indicates the competencies you have achieved and/or the areas where you are not yet competent. This document is referred to as an '*Assessment Summary*'.

If you have met the required competencies for all aspects of operating a EWP, the RTO will issue you a '*Statement of Attainment*'.

Is a licence required?

The licence is issued by the OHS agency following presentation of the '*Statement of Attainment*' and the Assessment Summary to them with the appropriate fee. The licence will be mailed out by the OHS agency at the address you nominate on your application for a licence.

Some RTOs **may** provide a service that includes arranging to have the licence issued to you. In this case, the OHS agency's licensing fee will be incorporated in the fee charged by the RTO.

What does your licence allow you to do?

The EWP licence simply means you have demonstrated the minimum competencies to perform the tasks outlined in this learning support material, and you may legally operate any EWP within the licence classification.

But it does not mean you have the skills to operate every EWP within the licence class.

Even though you hold a licence, your employer still has a duty of care to make sure you are provided with the necessary information, instruction, training and supervision to operate the EWP that are used at your place of work.

Extra training and supervision must be provided, for example, if purpose-designed attachments are being used.

Receiving your licence and beginning work

Once you have received your licence you must:

- sign it immediately, with your usual signature
- if you are asked, show it to your employer or an inspector of the occupational health and safety (OHS) authority in your state or territory.

Using your licence interstate

Licences are recognised throughout Australia. You do not have to change your licence if you are working interstate.

Replacing a lost licence

If your licence is lost, stolen or destroyed you must immediately notify the OHS authority in your State or Territory. You will need to complete a form to arrange for a replacement licence and pay the appropriate fee.

Appendix A: Abbreviations

EDD	Emergency descent device
EWP	Elevating work platform
OHS	Occupational health and safety
PPE	Personal protective equipment
PTO	Power take off
SWL	Safe working load

Appendix B: Contact details for OHS agencies

Workplace Health and Safety Queensland

Level 4
Lutwyche City Shopping Village
Lutwyche Road
LUTWYCHE QLD 4030
Postal Address:
PO Box 820
LUTWYCHE QLD 4030
Tel: 1300 369 915
Fax: 07 3247 9426

Internet: www.worksafe.qld.gov.au

WorkSafe Western Australia

5th Floor
1260 Hay Street
WEST PERTH WA 6005
Tel: 08 9327 8777
Fax: 08 9321 8973
Postal Address:
P O Box 294
WEST PERTH WA 6872

Internet: www.docep.wa.gov.au / www.safetyline.wa.gov.au

Email: safety@docep.wa.gov.au

WorkCover NSW

Head office
92-100 Donnison Street
GOSFORD NSW 2250
Tel: 02 4321 5000
Fax: 02 4325 4145
Office Hours: 8:30am - 5:00pm Monday to Friday
Postal address
WorkCover NSW
Locked Bag 2906,
LISAROW NSW 2252

WorkCover switchboard

Tel: 02 4321 5000
Fax: 02 4325 4145
TTY: 02 4325 4209

WorkCover Assistance Service

Tel: 13 10 50
Fax: 02 4325 5094
Hours: 8:30am - 5:00pm Monday to Friday

Victorian WorkCover Authority

Level 24
222 Exhibition Street
MELBOURNE VIC 3000
Tel: 03 9641 1555
Fax: 03 9641 1222
Postal Address:
GPO Box 4306
MELBOURNE VIC 3001

Workplace Services South Australia

Level 3
1 Richmond Road
KESWICK SA 5035
Tel: 08 8303 0400 (Reception)
Fax: 08 8303 0277
Postal Address:
GPO Box 465
ADELAIDE SA 5001
DX 715 ADELAIDE

Workplace Standards Tasmania

30 Gordon Hill Road
ROSNY PARK TAS 7018

Postal Address:
PO Box 56
ROSNY PARK TAS 7018

Tel: 03 6233 7657 (Outside Tasmania)
1300 366 322 (Local rate inside Tasmania)
Fax: 03 6233 8338
Email: wstinfo@dier.tas.gov.au

NT WorkSafe

Ground Floor
Minerals House
66 The Esplanade
DARWIN NT 0801
Postal Address:
GPO Box 4821
DARWIN NT 0801
Tel: 08 8999 5010
Fax: 08 8999 5141
Email: ntworksafe.deet@nt.gov.au

ACT WorkCover

Level 4
Eclipse House
197 London Circuit
CANBERRA CITY ACT 2601
Tel: (02) 6205 0200
Fax: (02) 6205 0336
Postal Address:
P O Box 224
CIVIC SQUARE ACT 2608

Email: workcover@act.gov.au

Comcare

Corporate Centre
GPO Box 9905
CANBERRA CITY ACT 2601
Level 1 (Reception)
14 Moore St
CANBERRA ACT 2600
Tel: 1300 366 979
Fax: 02 6257 5634